

CGC

SURGE
PROTECTION

CurrentGuard™

Installation, Operation and Maintenance Manual

PN 750-0098-002 B00

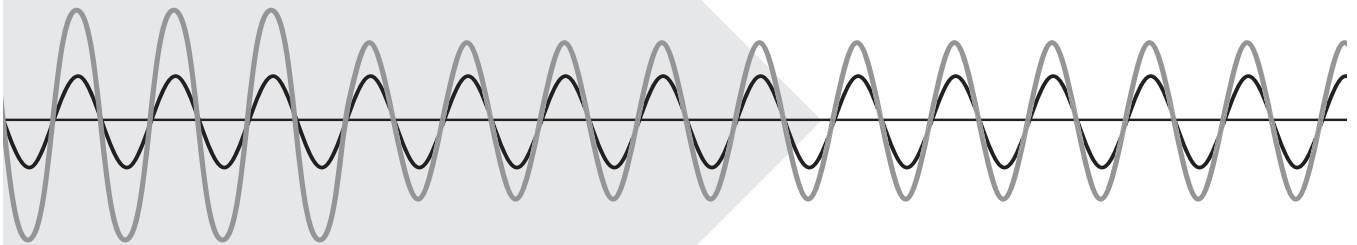

Surge Protective Devices
CurrentGuard™
Compact

Table of Contents

Guide to Installation and Assistance	3
Pre-Installation Checklist	4
Service Configurations	5
Plan Your Installation	6
Upstream Over-Current Protection Device	6
Mounting.	6
Basic Monitoring Option	8
Advanced Monitoring	8
Troubleshooting	10
Installation Assistance	10
Standards and Listings.	10
Return and Warranty Procedures.	10
Warranty Statement.	11

Guide to Installation and Assistance

Thank you for choosing the Current Technology® CurrentGuard™ Compact (CGC) series Surge Protective Device (SPD). We look forward to fulfilling your facility-wide surge protection needs.

Should you have questions about installing the CGC please call Current Technology® Technical Support at 800.238.5000 or 804-236-3300, Monday through Friday, 8:00 a.m. to 5:00 p.m. (EST). Or, email us at currenttechnology@tnbpowersolutions.com

This manual provides guidelines for the proper installation of the CurrentGuard Compact (CGC) devices. Proper product selection and compliance with these guidelines will help your new suppression system provide years of reliable service. If installers are unsure about the facility electrical configuration or have other installation-related questions, it is recommended they consult with a master electrician or other qualified electrical professional.

When shortcuts are taken or installation procedures are not followed, the CurrentGuard system may be damaged or may not provide adequate protection. It is extremely important to follow these installation procedures carefully.



△ W A R N I N G !

The CurrentGuard™ warranty is voided if the unit is damaged as a result of improper installation or the installer's failure to verify the following conditions prior to installation.

△ W A R N I N G !

HAZARDOUS VOLTAGES PRESENT: Improper installation or misapplication may result in serious personal injury/or damage to electrical system. Read the complete installation instructions before proceeding with installation. Remove all power to the electrical panel before installing or servicing the surge protective device (SPD).

IMPORTANT SAFETY INSTRUCTIONS: All work must be performed by licensed and qualified personnel. The electrical system must be properly grounded in accordance with the U.S. National Electrical Code, state and local codes or other applicable codes for this SPD to function properly. Do not connect CurrentGuard device to the line side of the main service breaker or disconnecting means. This device is suitable for installation where the available short circuit current is 200,000 rms symmetrical amperes up to 600VAC or less.

△ W A R N I N G !

Check to ensure that a proper bond is installed between neutral and ground at the transformer upstream from the CurrentGuard device (See NEC Article 250). If the transformer is not accessible, check the main service disconnect/panel for the N-G bond. Lack of a proper bond will damage CurrentGuard and void the warranty.

Pre-Installation Checklist

- Confirm that the voltage(s) and service configuration shown on the CurrentGuard product label are consistent with the voltage and service configuration of the facility. The model number can be found on the left side of the CurrentGuard unit. Each model number corresponds to the configurations printed in Table 1:

Model Number Scheme:

E.g.: CGC050-120/208-3GY-M

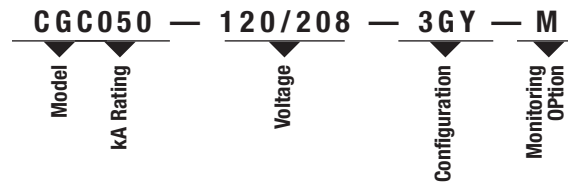

Table 1: Configuration Table

MODEL	NOMINAL VOLTAGE	L-N VOLTAGE RANGE	L-L VOLTAGE RANGE	CONFIGURATION
CGC050-120/240-2G	120/240	108-132	216-264	Split-Phase, 3-Wire + Ground
CGC050-120/208-3GY	120/208	108-132	187-229	3-Phase Wye, 4-Wire + Ground
CGC050-277/480-3GY	277/480	249-305	432-528	3-Phase Wye, 4-Wire + Ground
CGC050-240-3DG	240	N/A	216-264	3-Phase Delta, 3-Wire + Ground
Options Suffixes				
M	Advanced Monitoring (LEDs, Form "C" Contacts, Audible Alarm)			

- Confirm that the environmental conditions are consistent with the following ranges:
- Ambient Temperatures: Between -40° and +158°F.
 - Relative Humidity: Between 5% and 95% non-condensing.
 - Altitude: Less than 13,000 feet.
- Apply power to CurrentGuard by closing the over-current protection device or switch feeding the suppressor.



△ WARNING! It is recommended that the cover of the CurrentGuard unit along with its associated cabling be installed prior to applying power. The monitoring harness, which exits the epoxy and connects to J2 on the monitor board, contains line voltage when power is applied to the unit.

Service Configurations

Figures 1–3 show the electrical relationship between CurrentGuard and these three basic service configurations: Split-Phase, 3-Wire; 3-Phase, 4-Wire Wye; and 3-Phase, 3-Wire Delta.

Figure 1
Split-Phase, 3-Wire

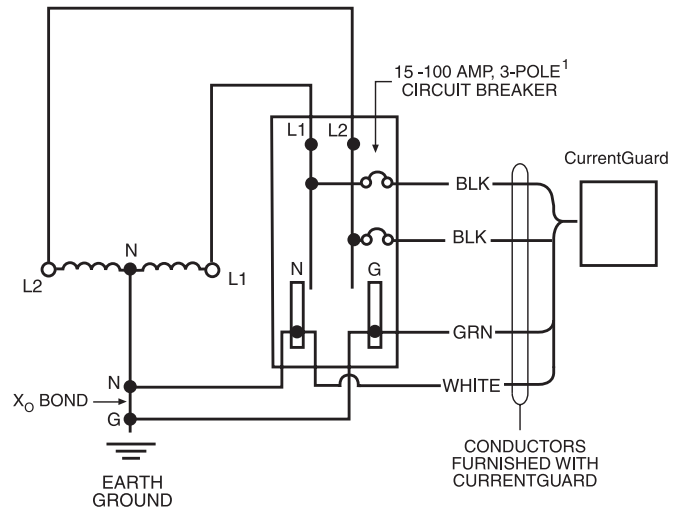

Figure 2
3-Phase, 4-Wire Wye

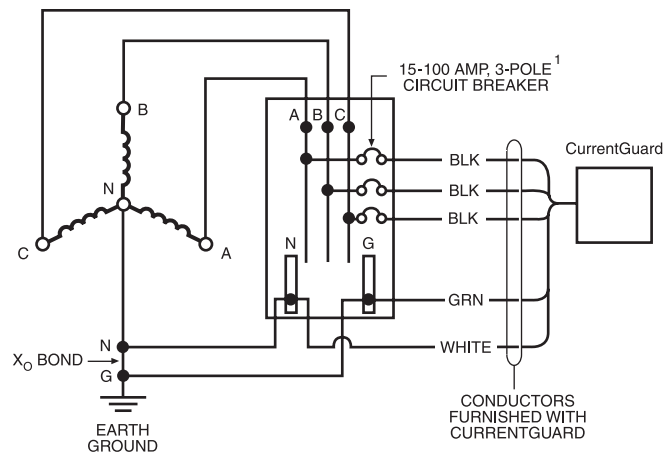
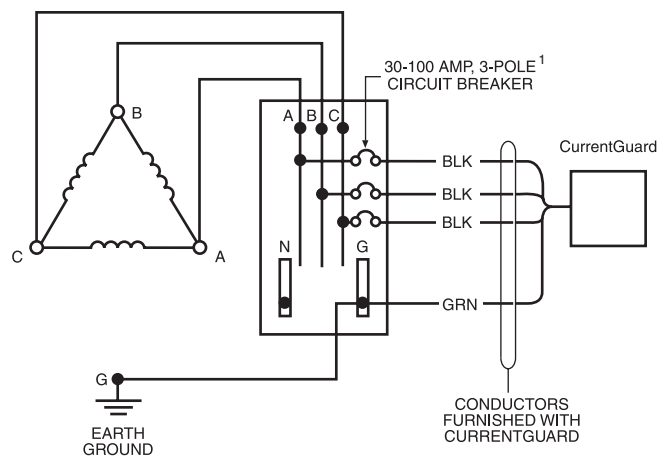

Figure 3
3-Phase, 3-Wire Delta



1. Optional – All CurrentGuard Compact units can be connected without an upstream breaker/fuse.

Plan Your Installation

Following all applicable National Electrical Code standards as well as state and local codes, connect phase, neutral* and ground to CurrentGuard. CurrentGuard units come with 36" of #10 AWG conductors. Ensure that the conductor lengths are kept as short and straight as possible.

CAUTION: CurrentGuard's performance will be limited severely if the conductors are (a) too long, (b) have too many bends or (c) have sharp bends.

The factors listed above should be addressed during the design of an installation to reserve a suitable place for CurrentGuard next to its point of connection to the electrical system. The selected mounting location should allow for the shortest possible conductor runs and a direct route with a minimum of bends. If bends are required, they should be *sweeping* bends. Do not make sharp 90° bends for appearance purposes because they will severely decrease the effectiveness of CurrentGuard.

Binding or twisting conductors together using tie-wraps or electrical tape increases the protection performance of the device.

**The 3-wire plus ground Delta CurrentGuard does not have a neutral conductor*

Upstream Over-Current Protection Device

All CurrentGuard series units must be connected in parallel with the electrical system. CurrentGuard units have built-in over-current fusing rated at 200,000 rms symmetrical ampere up to 600VAC or less and can be connected directly to the electrical distribution system bus without an upstream over-current protection device (OCPD). However, the use of an external OCPD is recommended.

If the SPD is connected to a dedicated overcurrent protection device, a 30A breaker is recommended (15A minimum, 200A maximum). The advantage of using a dedicated over-current device for the SPD (even if the upstream breaker is 200A or less) is that it allows the SPD to be de-energized during service without disturbing the electrical service to the rest of the facility.

Mounting

CurrentGuard can be mounted in a variety of methods. The basic method is to wall mount using the mounting feet attached to the base of the enclosure. CurrentGuard can also be mounted even (or flush-mount) to the exterior wall surface. Mount CurrentGuard using construction methods and hardware appropriate for your site. The CurrentGuard enclosure is designed with a 3/4-inch myers hub which will accept rigid or IMC conduit. See Figure 4 for enclosure and mounting dimensions.

Figure 4
Enclosure/Mounting Dimensions
Without Flush Plate

DIM	Inches	(mm)
H1	6.00	(152.4)
H2	6.75	(171.5)
H3	7.50	(190.5)
W1	6.00	(152.4)
W2	4.00	(101.6)
D1	4.16	(105.7)
D2	2.50	(63.5)

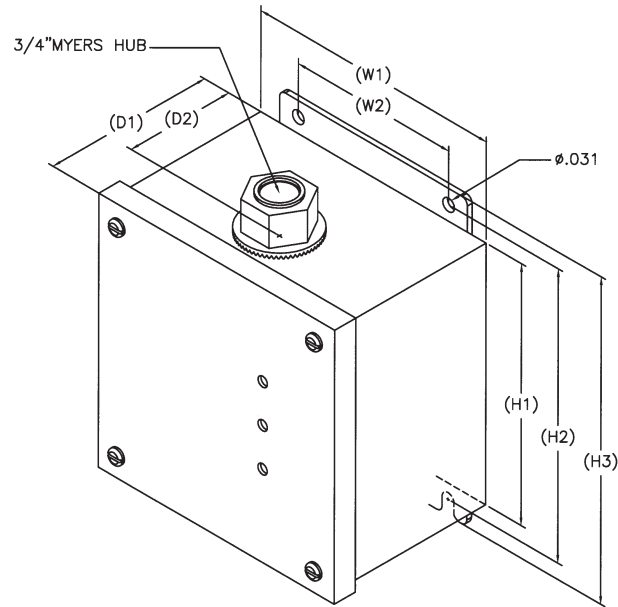

Optional flush-mount plate, part number CGC-FMP, can be purchased for flush-mount installation. Typically a cutout, larger than the CurrentGuard enclosure, is created in the drywall or other finish material. See Figure 5 for the recommended cutout gap (dimensions L1 and L2). Use the flush-mount plate to hide the gap between the enclosure and the cutout edges. Prior to installation, attach the plate to the enclosure using the existing cover screws.

Figure 5
Flush-Mount Plate Dimensions
With Flush Plate

DIM	Inches	(mm)
H2	10.50	(266.7)
L1	7.00	(177.8)
L2	8.50	(215.9)
M2	8.00	(203.2)
N2	4.75	(120.6)
W2	9.00	(228.6)

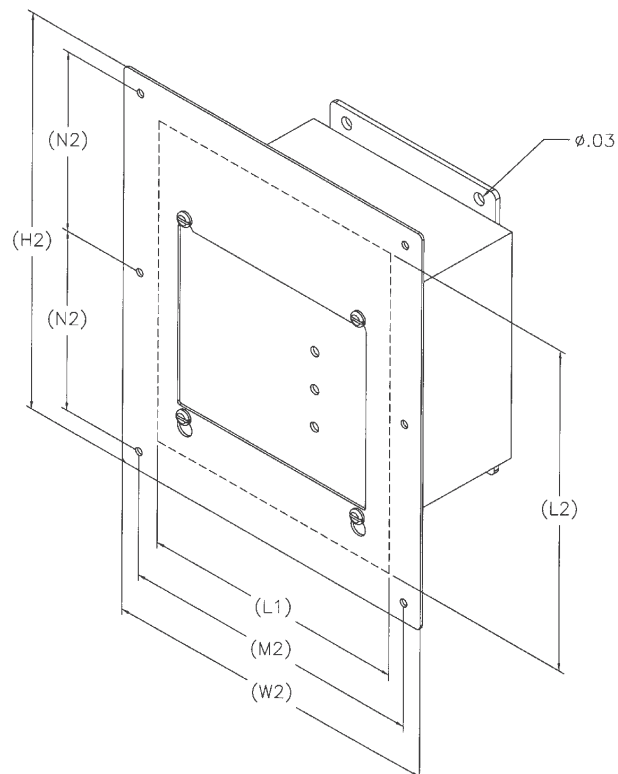

Electrical Connections

CAUTION: Prior to installation ensure the system configuration and voltage is equivalent to the CurrentGuard unit being installed.

The CurrentGuard units come with 36" of #10AWG conductors. Each phase conductor is labeled (Phase A, B or C). Ensure that the conductor lengths are kept as short and straight as possible. On all high-leg delta systems, the high-leg (208V L-N) must be connected to the Phase B of the SPD (color-coded orange according to NEC).

** The 3-wire plus ground Delta CurrentGuard does not have a neutral conductor.*

Basic Monitoring Option



Verify that all "Phase Protection Status" indicating lights are illuminated.

Advanced Monitoring

For CurrentGuard Compact Units (model number ends with -M)

Verify that all "Phase Protection Status" indicating lights are illuminated. The "Service Required" indicating light illuminates only upon failure of one or more phases (indicating an alarm condition). Audible alarm should not operate under normal conditions. The audible alarm can be "muted" by pressing the "ALARM SILENCE" button, which subsequently will illuminate the "ALARM SILENCED" light. Pressing the "ALARM SILENCE" button again will enable the alarm.

Remote Monitoring

All CurrentGuard units with the -M monitoring option come with one set of Form "C" dry relay contacts for the surge protective device status. These contacts are for connection to a user-provided remote alarm and monitoring circuit. The relay contacts are rated 150VDC/125VAC with maximum switching power of 30WDC/60VA AC.

When input power is present on all phases, terminals "NO" (Normally Open) and "COM" (Common) are an open circuit and terminals "NC" (Normally Closed) and "COM" are a closed circuit. The contacts change state when the unit has encountered failure to one or more phases.

The CGC comes pre-wired with 36" of #20AWG conductors.

Connecting Form "C" Dry Contacts

See Figure 6 for the Form "C" wiring and contact configuration.

Use butt splices within the panelboard to connect the Form "C" leads to the user's monitoring circuits. Alternatively, install a junction box between the JSP and the panelboard to connect Form "C" leads to user's monitoring circuits. If the Form "C" contacts are not used, user has the option of either cutting off the leads or coiling up the leads and saving them for potential future use. Consult applicable local codes to ensure proper installation.

Figure 6
Wire Connections
Contacts shown in de-energized state
(alarm condition).

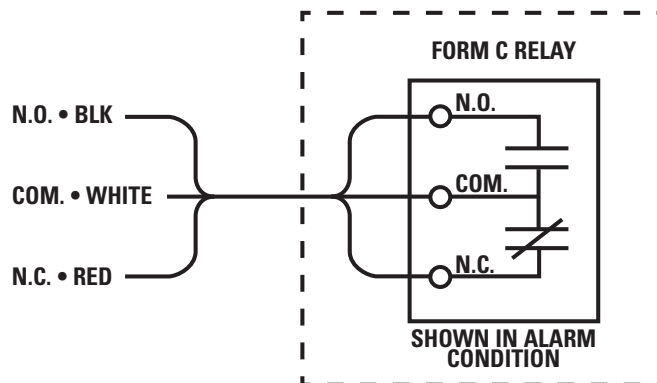

Troubleshooting

Your CurrentGuard system does not require scheduled maintenance. The unit's heavy-duty construction is designed to provide years of uninterrupted service. The unit contains no serviceable parts.

INDICATION	PROCEDURE
One or more phase protection status indicating lights are off, and Form "C" alarm contacts have changed state	Verify that the input power feeding CurrentGuard is energized using a voltage tester. If power is present, contact factory for assistance: 800-238-5000

Installation Assistance

Our staff is available to support you.

Monday through Friday, 8:00 a.m to 5:00 p.m. (EST):
800.238.5000 or 804.236.3300.
currenttechnology@tnbpowersolutions.com

Standards and Listings

The following standards and listings apply to the CGC product line:

- UL Listed 1449 4th Edition, cUL, and UL 1283
- Meets Requirements for UL 96A
- Compliant to IEEE C62.41.1-2002, C62.41.2-2002 and C62.45-2002
- NFPA 70 [NEC], Article 285
- RoHS Compliant

Returns and Warranty Procedures

CurrentGuard Compact units are warranted for a period of 10 years from date of purchase. In the event that any module or subassembly within the SPD fails to perform as specified during the warranty period, call our Technical Support at 800.238.5000 to obtain a Return Material Authorization (RMA) number. We will immediately ship a replacement for the defective parts free of charge (installation labor and site preparation excluded). Return the defective parts to Current Technology within 30 days of receiving the replacement. Failure to return the defective parts will result in billing for the replacement parts. To help expedite the return procedures, please have the following information at hand when you contact Current Technology:

INFORMATION	EXAMPLE
Model Number	CGC050-120/208-3GY
Serial Number	15478-0113-001
Date of Purchase	January 2, 2013
Sales Order Number	15478
Description of Failure	Phase A light is off
Desired Action from Current Technology	Replace

10 Year Limited Warranty

Thomas & Betts Power Solutions warrants that CurrentGuard Compact surge protective device (the “Product”), shall meet applicable industry standards and specifications and be free from defects in materials and/or workmanship. Should any failure of the Product to conform to this warranty appear within the warranty period, Thomas & Betts Power Solutions shall either repair or replace the defective Product, or part thereof, upon return to Thomas & Betts Power Solutions manufacturing facility in Richmond, Virginia with transportation charges prepaid. The applicable warranty period is outlined below in the warranty period section.

Thomas & Betts Power Solutions shall have no liability under this warranty for any problems or defects directly or indirectly caused by misuse of the Product, alteration of the Product (including removal of any warning labels), accidents, or improper installation, application, operation, or repair of the Product.

THIS WARRANTY REPRESENTS THE ENTIRE WARRANTY OF THOMAS & BETTS POWER SOLUTIONS. ALL OTHER WARRANTIES EXPRESS OR IMPLIED, ORAL OR WRITTEN, INCLUDING, BUT NOT LIMITED TO, THE WARRANTIES OF MERCHANTABILITY AND FITNESS FOR A PARTICULAR PURPOSE ARE HEREBY DISCLAIMED.

The liability of Thomas & Betts Power Solutions under this warranty is expressly limited to the replacement or repair of the defective part thereof, at Thomas & Betts Power Solutions’ sole option.

IN NO EVENT SHALL THOMAS & BETTS POWER SOLUTIONS BE LIABLE FOR SPECIAL, INCIDENTAL, OR CONSEQUENTIAL DAMAGES OF ANY KIND OR CHARACTER, NOR SHALL THOMAS & BETTS POWER SOLUTIONS’ LIABILITY EVER EXCEED THE PURCHASE PRICE PAID FOR SUCH DEFECTIVE PRODUCT.

This warranty is not transferable and may only be enforced by the sole purchaser. Claims under this warranty must be submitted to Thomas & Betts Power Solutions within thirty (30) days of discovery of any CurrentGuard product defect.

Warranty Period

CurrentGuard™ Compact 10 Years from original date of purchase

Model #

Date of Purchase

Date Installed

Installer



Thomas & Betts Power Solutions
5900 Eastport Blvd. • Richmond, VA 23231-4453 USA
Tel: (804) 236-3300 • Toll free: (800) 238-5000 • Fax: (804) 236-4841
tnbpowersolutions.com/current_technology

© 2018, Thomas & Betts Power Solutions, LLC. • Thomas & Betts Power Solutions, LLC., is a wholly owned subsidiary of Thomas & Betts Corporation. Current Technology® and CurrentGuard™ are trademarks of Thomas & Betts International, Inc. • Specifications are subject to change without notice. • Visit our website for latest revisions.